

# Assembly and operating instructions

DULCODOS® Pool

DSPa, PR0

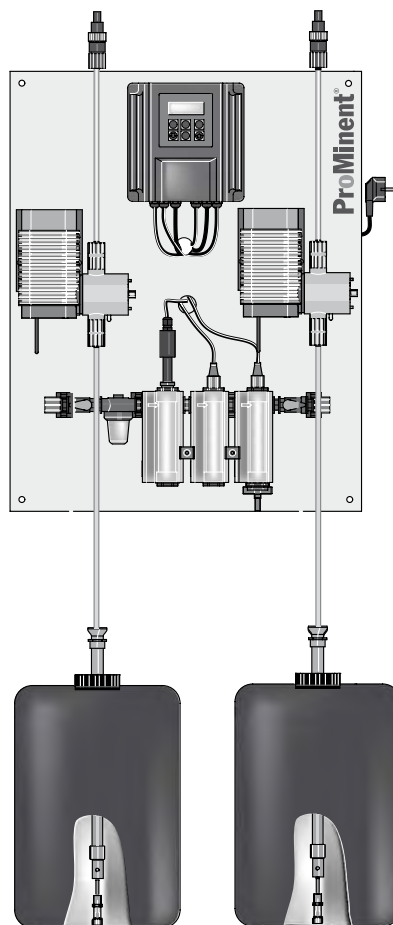

A0953

**Please carefully read these operating instructions before use! · Do not discard!  
The operator shall be liable for any damage caused by installation or operating errors!  
Technical changes reserved.**

ProMinent Dosiertechnik GmbH  
Im Schuhmachergewann 5 - 11  
69123 Heidelberg  
Telephone: +49 6221 842-0  
Fax: +49 6221 842-419  
email: [info@prominent.de](mailto:info@prominent.de)  
Internet: [www.prominent.com](http://www.prominent.com)

986589, 1, en\_GB

### General non-discriminatory approach

In order to make it easier to read, this document uses the male form in grammatical structures but with an implied neutral sense. It is aimed equally at both men and women. We kindly ask female readers for their understanding in this simplification of the text.

### Supplementary information

Read the following supplementary information in its entirety!

The following are highlighted separately in the document:

- Enumerated lists
- ➔ Instructions
  - ⇒ Results of the instructions

### Information



*This provides important information relating to the correct operation of the system or is intended to make your work easier.*

### Safety information

Safety information are provided with detailed descriptions of the endangering situation, see ↪ *Chapter 3.2 'Explanation of the safety information' on page 9*

## Table of contents

<b>1</b>	<b>Identity code</b> .....	<b>5</b>
<b>2</b>	<b>About this product</b> .....	<b>7</b>
	2.1 Overview of equipment.....	7
<b>3</b>	<b>Safety and responsibility</b> .....	<b>9</b>
	3.1 Users' qualifications.....	9
	3.2 Explanation of the safety information.....	9
	3.3 General Safety Information.....	11
	3.4 Correct and proper use.....	12
<b>4</b>	<b>Storage and transport</b> .....	<b>13</b>
<b>5</b>	<b>Assembly</b> .....	<b>14</b>
	5.1 Wall mounting.....	14
	5.2 Hydraulic installation.....	15
	5.2.1 Metering system.....	16
	5.2.2 Sensors.....	18
	5.3 Electrical installation.....	18
<b>6</b>	<b>Start up</b> .....	<b>19</b>
	6.1 Adjust the flow sensor switching point.....	20
	6.2 Priming and bleeding.....	20
	6.3 Calibration.....	21
<b>7</b>	<b>Maintenance and faults</b> .....	<b>24</b>
	7.1 Maintenance work.....	24
	7.2 Check sensors.....	25
	7.3 Troubleshooting.....	26
	7.4 Disposal of used parts.....	27
<b>8</b>	<b>Technical data</b> .....	<b>28</b>
<b>9</b>	<b>Systems</b> .....	<b>29</b>
	9.1 Spare parts and accessories.....	29
	9.2 EC Declaration of Conformity.....	30
<b>10</b>	<b>Index</b> .....	<b>31</b>

# 1 Identity code

DSPa	DULCODOS® Pool			
	Measured variable:			
PR0	pH/ORP (DSR)			
	Hardware auxiliary functions:			
0	Standard			
	Software auxiliary functions:			
0	none			
	Communication interfaces:			
0	none			
	Electrical connection:			
A	230 V, 50/60 Hz, European standard plug			
B	230 V, 50/60 Hz, Swiss plug			
	Sensor equipment:			
0	with sensors			
A	Measured variable PR0 without sensors			
	Version:			
0	with logo			
1	without logo			
	Language:			
D	German	I	Italian	
E	English	N	Dutch	
F	French	R	Russian	
G	Czech	S	Spanish	
	Metering pumps for acid / alkali:			
0	without metering pumps			
	DULCO®flex (hose pump):			
1	0.8 l/h (DULCO®flex DF2a 0208)			
2	1.6 l/h (DULCO®flex DF2a 0216)			
3	2.4 l/h (DULCO®flex DF2a 0224)			
	alpha (motor-driven metering pump):			
4	1.8 l/h (alpha ALPc 1002 PPE)			
5	3.5 l/h (alpha ALPc 1004 PPE)			
	Multifunctional valve for acid/alkali pump:			
0	none			
1	with MFV (only for alpha)			
	Metering pumps for disinfection:			
0	without metering pumps			
	DULCO®flex (hose pump):			
1	0.8 l/h for up to 45/10 m <sup>3</sup> /h circulation HB/FB*			

## Identity code

DSPa	DULCODOS® Pool											
											2	1.6 l/h for up to 100/20 m <sup>3</sup> /h circulation HB/ FB*
											3	2.4 l/h for up to 140/30 m <sup>3</sup> /h circulation HB/ FB*
											alpha (motor-driven metering pump):	
											4	1.8 l/h for up to 100/20 m <sup>3</sup> /h circulation HB/ FB*
											5	3.5 l/h for up to 200/40 m <sup>3</sup> /h circulation HB/ FB*
											Multifunctional valve for disinfection pump	
											0	none
											1	with MFV (only for alpha)
											Assembly	
											0	supplied loose without assembly plate
											1	mounted on a base plate
											Certification	
											0	with CE mark

\* calculated for 12 percent sodium-calcium hypochlorite

- HB = Indoor swimming pool
- FB = Outdoor swimming pool

## 2 About this product

DULCODOS® Pool metering systems are specifically designed for the treatment of swimming pool water. Ready mounted, fully-wired and ready for use, they take on the job of pH value adjustment and disinfection with chlorine.

DULCODOS® Pool metering systems are equipped with all necessary components and assembled on a plate.

- Sensors
- Controller
- Metering pumps

### 2.1 Overview of equipment

#### Components

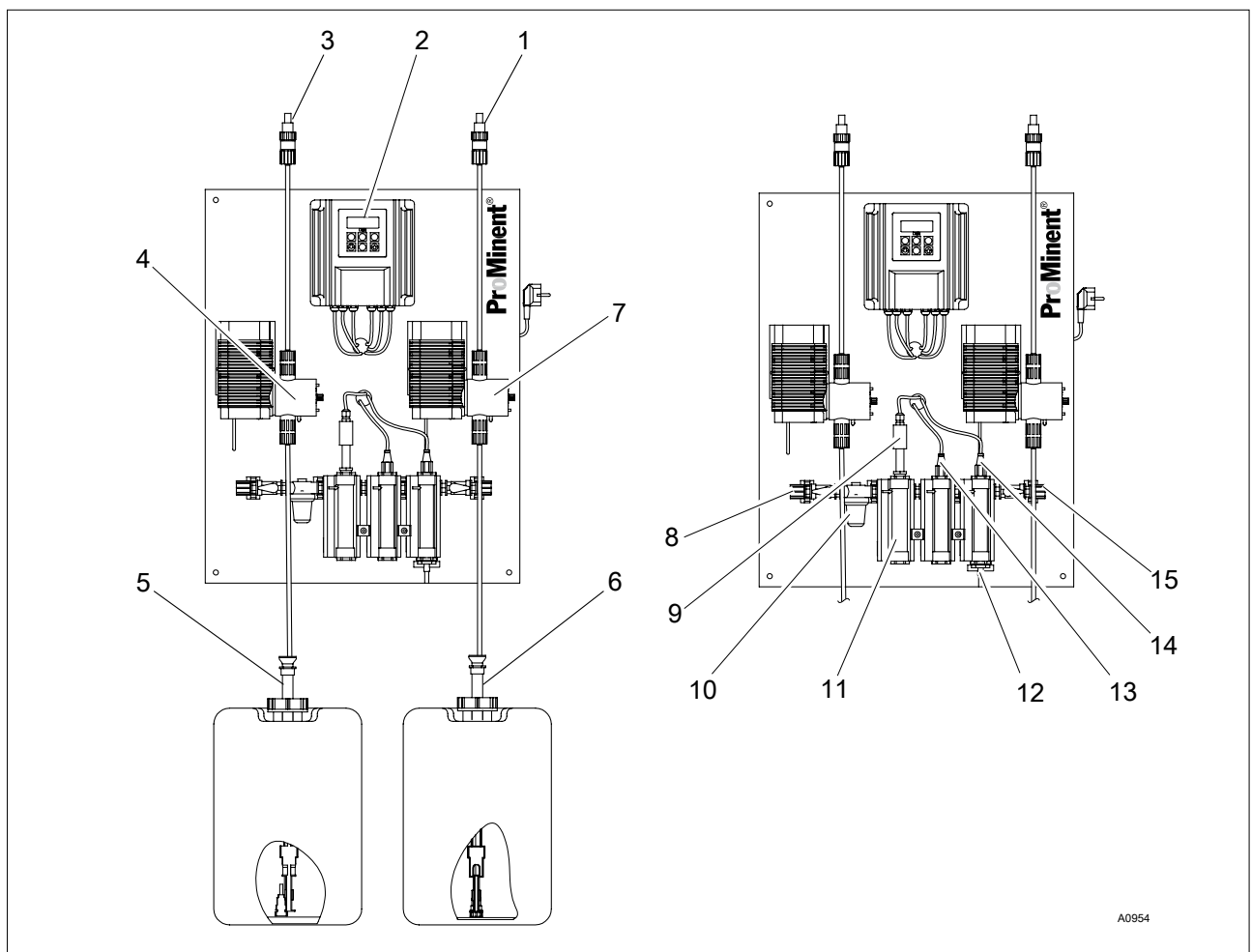
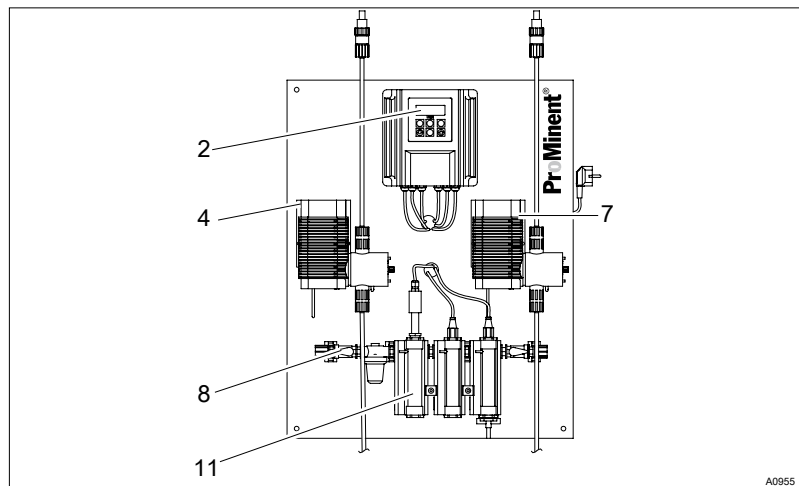

Fig. 1: Overview of equipment of DULCODOS® Pool metering system PR0 (with all options and alpha metering pumps)

- |    |                                   |     |                              |
|----|-----------------------------------|-----|------------------------------|
| 1. | Injection valve for disinfection  | 9.  | Flow sensor                  |
| 2. | Controller                        | 10. | Dirt filter                  |
| 3. | Injection valve for acid          | 11. | Flow module with flow sensor |
| 4. | Acid metering pump                | 12. | Sampling tap                 |
| 5. | Suction assembly for acid         | 13. | pH sensor*                   |
| 6. | Suction assembly for disinfection | 14. | ORP sensor*                  |
| 7. | Metering pump for disinfection    | 15. | Ball valve, outlet side      |
| 8. | Ball valve, inlet side            |     |                              |

\* To be assembled on the customer's side. These components are ready for subsequent installation, but are supplied separately to avoid damage in transit.

### Control elements



*Fig. 2: Control elements of the DULCODOS® Pool metering system PRO (with all options and alpha metering pumps)*

The following are used as control elements:

2. Controller keys and display
4. Concealed, stroke adjustment dial inside metering pump
7. Concealed, stroke adjustment dial inside metering pump
8. Ball valve, in-line probe housing, inlet side
11. Flow meter (by scale)

### 3 Safety and responsibility

#### 3.1 Users' qualifications



**WARNING!**

**Danger of injury with inadequately qualified personnel!**

**The operator of the plant / device is responsible for ensuring that the qualifications are fulfilled.**

If inadequately qualified personnel work on the unit or loiter in the hazard zone of the unit, this could result in dangers that could cause serious injuries and material damage.

- All work on the unit should therefore only be conducted by qualified personnel.
- Unqualified personnel should be kept away from the hazard zone

Training	Definition
Instructed personnel	An instructed person is deemed to be a person who has been instructed and, if required, trained in the tasks assigned to him/her and possible dangers that could result from improper behaviour, as well as having been instructed in the required protective equipment and protective measures.
Trained user	A trained user is a person who fulfils the requirements made of an instructed person and who has also received additional training specific to the system from ProMinent or another authorised distribution partner.
Trained qualified personnel	A qualified employee is deemed to be a person who is able to assess the tasks assigned to him and recognize possible hazards based on his/her training, knowledge and experience, as well as knowledge of pertinent regulations. The assessment of a person's technical training can also be based on several years of work in the relevant field.
Electrician	Electricians are deemed to be people, who are able to complete work on electrical systems and recognize and avoid possible hazards independently based on his/her technical training and experience, as well as knowledge of pertinent standards and regulations.  Electricians should be specifically trained for the working environment in which they are employed and know the relevant standards and regulations.  Electricians must comply with the provisions of the applicable statutory directives on accident prevention.
Customer Service department	Customer Service department refers to service technicians, who have received proven training and have been authorised by ProMinent to work on the system.



**Note for the system operator**

*The pertinent accident prevention regulations, as well as all other generally acknowledged safety regulations, must be adhered to!*

#### 3.2 Explanation of the safety information

**Introduction**

These operating instructions provide information on the technical data and functions of the product. These operating instructions provide detailed safety information and are provided as clear step-by-step instructions.

The safety information and notes are categorised according to the following scheme. A number of different symbols are used to denote different situations. The symbols shown here serve only as examples.



**DANGER!**

**Nature and source of the danger**

Consequence: Fatal or very serious injuries.

Measure to be taken to avoid this danger

Danger!

- Denotes an immediate threatening danger. If this is disregarded, it will result in fatal or very serious injuries.



**WARNING!**

**Nature and source of the danger**

Possible consequence: Fatal or very serious injuries.

Measure to be taken to avoid this danger

Warning!

- Denotes a possibly hazardous situation. If this is disregarded, it could result in fatal or very serious injuries.



**CAUTION!**

**Nature and source of the danger**

Possible consequence: Slight or minor injuries, material damage.

Measure to be taken to avoid this danger

Caution!

- Denotes a possibly hazardous situation. If this is disregarded, it could result in slight or minor injuries. May also be used as a warning about material damage.



**NOTICE!**

**Nature and source of the danger**

Damage to the product or its surroundings

Measure to be taken to avoid this danger

Note!

- Denotes a possibly damaging situation. If this is disregarded, the product or an object in its vicinity could be damaged.



***Type of information***

*Hints on use and additional information*

*Source of the information, additional measures*

*Information!*

- *Denotes hints on use and other useful information. It does not indicate a hazardous or damaging situation.*

### 3.3 General Safety Information

**WARNING!****Live parts!**

Possible consequence: Fatal or very serious injuries

- Measure: Disconnect the mains power supply prior to opening the housing
- De-energise damaged, defective or manipulated units by disconnecting the mains plug

**WARNING!****Unauthorised access!**

Possible consequence: Fatal or very serious injuries

- Measure: Ensure that there can be no unauthorised access to the unit

**WARNING!****Operating errors!**

Possible consequence: Fatal or very serious injuries

- The unit should only be operated by adequately qualified and technically expert personnel
- Please also observe the operating instructions for controllers and fittings and any other component groups, such as sensors, measuring water pumps ...
- The operator is responsible for ensuring that personnel are qualified

**CAUTION!****Electronic malfunctions**

Possible consequence: Material damage to destruction of the unit

- The mains connection cable and data cable should not be laid together with cables that are prone to interference
- Measure: Take appropriate interference suppression measures

**NOTICE!****Correct and proper use**

Damage to the product or its surroundings

- The unit is not intended to measure or regulate gaseous or solid media
- The unit may only be used in accordance with the technical details and specifications provided in these operating instructions and in the operating instructions for the individual components



**NOTICE!**

**Correct sensor operation / Run-in time**

Damage to the product or its surroundings

- Correct measuring and dosing is only possible if the sensor is working perfectly
- It is imperative that the run-in times of the sensors are adhered to
- The run-in times should be allowed for when planning initial operation
- It may take a whole working day to run-in the sensor
- Please read the operating instructions for the sensor



**NOTICE!**

**Correct sensor operation**

Damage to the product or its surroundings

- Correct measuring and dosing is only possible if the sensor is working perfectly
- Check and calibrate the sensor regularly



**NOTICE!**

**Compensation of control deviations**

Damage to the product or its surroundings

- This controller cannot be used in control circuits which require rapid compensation (< 30 s)

### 3.4 Correct and proper use



**NOTICE!**

**Compensation for control deviations**

Damage to the product or its surroundings

- The controller can be used in processes, which require compensation of > 30 seconds



**NOTICE!**

**Correct and proper use**

The unit is intended to measure and regulate liquid media. The marking of the measured variables is located on the controller and is absolutely binding.

The unit may only be used in accordance with the technical details and specifications provided in this operating manual and in the operating manuals for the individual components (such as, for example, sensors, fittings, calibration devices, metering pumps etc.).

Any other uses or modifications are prohibited.

## 4 Storage and transport

Ambient conditions for storage and transport without sensors



### CAUTION!

- Prior to storage or transport, the DULCODOS® Pool metering systems must be free from feed chemicals and water
- Rinse out the media carrying parts, including the tubes using clean, pure water
- Transport and store the DULCODOS® Pool metering systems in their original packaging
- Also protect the packaged DULCODOS® Pool metering systems against damp, exposure to chemicals and mechanical effects
- Please also observe the operating instructions for controllers and fittings and other units, such as sensors, filters, metering pumps ...

Storage temperature: 0 ... 50 °C

Air humidity: < 95% relative air humidity, non-condensing



### NOTICE!

If the DULCODOS® Pool metering systems are stored as an assembly with the sensors, then the storage and transport conditions must be appropriate for the component with the least resistance to external influences.

## 5 Assembly

### 5.1 Wall mounting



Secure the metering system perpendicular and upright on a wall or a stable mounting system.

The metering system should be freely accessible.

Select the mounting height you require so that:

- The controller's display can be easily read
- There is still space for maintenance work beneath the in-line probe housing (100 mm)
- There is still room for the chemical storage tank (600 mm)
- The fluid level of the full chemical storage tanks is below the metering pumps
- The maximum priming lift of the metering pumps is not exceeded.

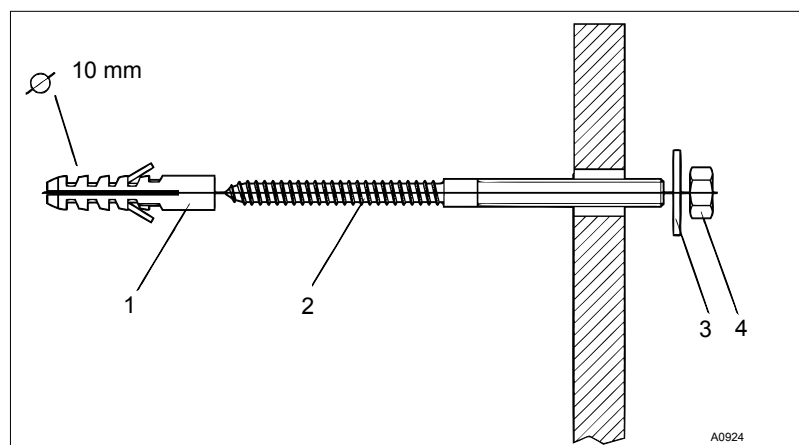
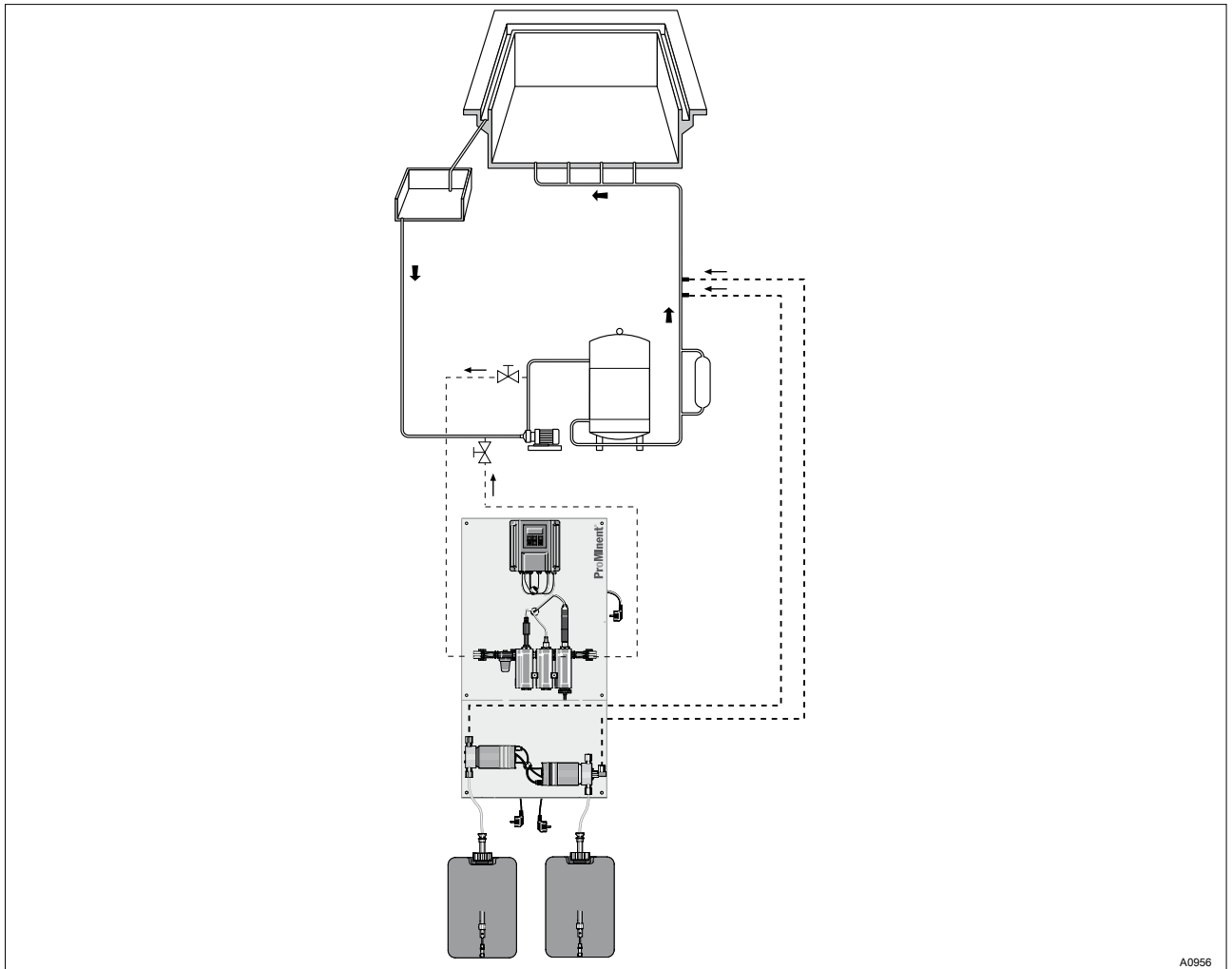

Fig. 3: Hanger bolt

- 1 Rawplug (type dependent on substrate and according to stipulations of the rawplug manufacturer)
- 2 Hanger bolt
- 3 U-washer
- 4 Hexagon nut

## 5.2 Hydraulic installation



A0956

*Fig. 4: Indoor swimming pool: hydraulic connection of the swimming pool metering system to the swimming pool installation*

Advantage: "Direct" measured values without depletion  
 Disadvantage: In-line probe housing can become dirty

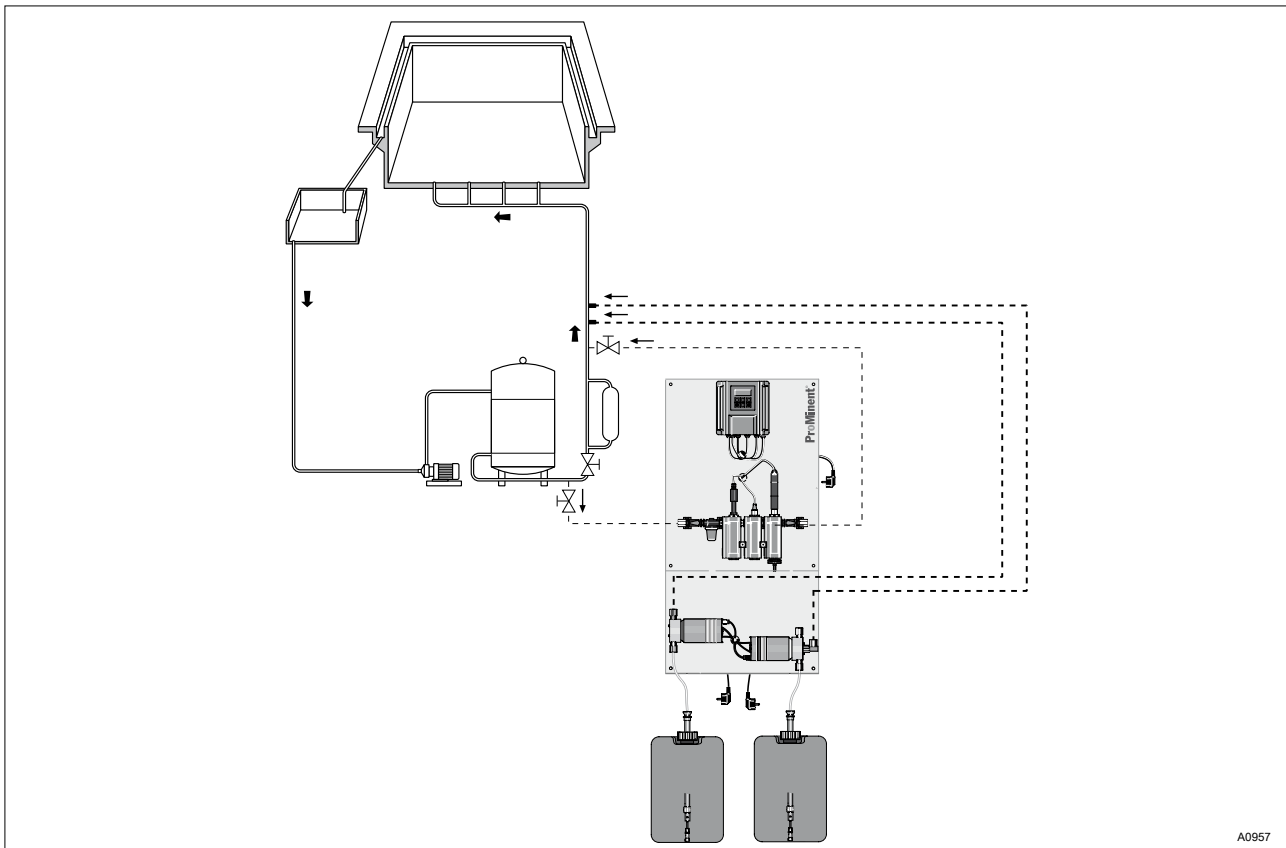

A0957

Fig. 5: Outdoor swimming pool: hydraulic connection of the swimming pool metering system to the swimming pool installation

Advantage: In-line probe housing cannot become dirty  
 Disadvantage: Measured values with depletion

### 5.2.1 Metering system



**NOTICE!**

**Maximum permissible operating pressure of in-line probe housing**

Limit the pressure to a maximum of 2 bar (at 30 °C) directly at the sample water extraction point using a pressure reducer, otherwise the maximum permissible operating pressure of the in-line probe housing will be exceeded.

Do not allow a back pressure of more than 2 bar (at 30 °C) to build up at the outlet, otherwise the maximum permissible operating pressure of the in-line probe housing will be exceeded.

1. ➤ With flow sensor: Push the flow sensor into the in-line probe housing and tighten the reducing nipple and the mounting clip
2. ➤ Route the sample water feed via a ball valve from the filter circuit to the in-line probe housing, see figures above
3. ➤ Route the sample water feed via a ball valve from the filtration circuit to the in-line probe housing, see figures above
4. ➤ Install a 1/2" straight union on the filtration circuit pipe for each injection valve
5. ➤ Screw the injection valves into a straight union of the filtration circuit pipe

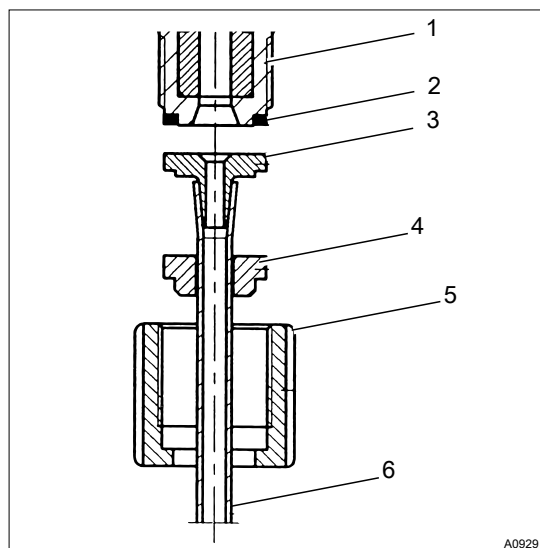

Fig. 6: Connect the tube using the connector kit

1. Valve
2. O-ring
3. Nozzle
4. Clamp ring
5. Union nut
6. Hose

6. ➔ Connect the suction hose of the suction assembly to the connector kit on the liquid end
7. ➔ Connect the pressure hose to the pressure connector using the connector kit
8. ➔ Connect the pressure hose to the injection valve using the connector kit

**Testing the hydraulic installation of the metering system:**

**i** To ensure reliable measuring and control, the sample water must be free from air bubbles.

1. ➔ Set a flow of 20 ... 60 l/h using the stopcock (read-off at the top edge of the float).
2. ➔ Check the hydraulic leak-tightness of the system (escaping liquid, continuous air bubbles in the in-line probe housing, ...)
  - ⇒ Tighten the threaded connectors if necessary.

**Check the system for negative pressure**

1. ➔ **i** Have a collecting vessel at the ready

Open the sampling tap

2. ➔ If water flows out of the sampling tap, the system is not under negative pressure and is working correctly

**i** If air is drawn in, this means that there is negative pressure in the system. In this case, throttle the valve at the point at which the sample water pipe enters the filtration circuit - the pressure should not exceed 2 bar.

3. ➤ Use the stopcock on the sample water drain to finely adjust the system

### 5.2.2 Sensors



*Observe the operating instructions for the sensors.*

1. ➤ Close the shut-off valves upstream and downstream of the in-line probe housing
2. ➤ Remove the transparent protective cap from the ball-shaped end of the pH sensor
3. ➤ Manually screw both the pH sensor and the redox sensor into separate threaded holes on the in-line probe housing. Then carefully tighten using an SW 17 open-ended spanner until the threaded connector is tight
4. ➤ Testing the sensors' hydraulic installation: Adjust the flow using the shut-off valve to 20... 60 l/h
  - ⇒ Check whether the threaded connectors on the in-line probe housing are tight.

### 5.3 Electrical installation

1. ➤ Screw the orange-coloured SN6 plug onto the sensors
2. ➤ Plug the mains plug for the metering system into a socket

## 6 Start up

### Preparation:



#### WARNING!

##### Danger from hazardous substances!

Possible consequence: Fatal or very serious injuries.

Please ensure when handling hazardous substances that you have read the latest safety data sheets provided by the manufacture of the hazardous substance. The actions required are described in the safety data sheet. Check the safety data sheet regularly and replace, if necessary, as the hazard potential of a substance can be re-evaluated at any time based on new findings.

The system operator is responsible for ensuring that these safety data sheets are available and that they are kept up to date, as well as for producing an associated hazard assessment for the workstations affected.



#### WARNING!

##### Acid and chlorine products

Cause: Never bring together acid and chlorine products, like sodium-calcium hypochlorite as this will produce a toxic chlorine gas.

Possible consequence: Fatal or very serious injuries from chlorine gas.

Action: refer to the current safety data sheets for the feed chemical.



#### CAUTION!

Wear suitable protective equipment (gloves, protective goggles,...) when commissioning.

Refer to the latest safety data sheets on the feed chemicals.



#### NOTICE!

The sampling tap must be closed otherwise sample water will escape.



*The service technician is responsible for instructing the operating and maintenance personnel during commissioning.*



#### **Metering pumps alpha**

*The following applies to metering pumps alpha:*

- *The acid metering pump has a grey dosing head*
- *The chlorine metering pump has a transparent clear acrylic dosing head*



**Maximum permissible operating pressure:**  
*In the sample water line: 2 bar at 30 °C (sample water)*

1. ➤ Tighten all threaded connectors prior to initial commissioning
2. ➤ Open the shut-off valves downstream of the metering pumps, in the sample water line and also the shut-off valves in your system
3. ➤ Insert the suction lances into the relevant chemical storage tanks for acid or disinfectant (e.g. sodium-calcium hypochlorite)
4. ➤ Plug the mains plug into the socket and switch on the mains voltage

### 6.1 Adjust the flow sensor switching point

The flow sensor should switch when the flow falls (flow sensor is connected as an NC).



*Sample water may escape.*

1. ➤ Adjust the flow to 50 l/h using the ball valve
2. ➤ Hold the flow sensor in place and loosen the mounting clip a little
3. ➤ Press the float to 40 l/h using the flow sensor
  - ⇒ The error message should disappear.
4. ➤ Hold the flow sensor in this position and tighten the mounting clip
5. ➤ Then re-adjust the flow required using the ball valve
6. ➤ Acknowledge any error message that occurs
7. ➤ Reset any possible consequences of this in the overall installation
8. ➤ Check the threaded connector for leak-tightness

### 6.2 Priming and bleeding

Priming acid (liquid ends without bleed valve):



**CAUTION!**

**Only with liquid ends without bleed valve:**

Wear suitable protective equipment (protective goggles, protective gloves,...).

The priming process can be cancelled using the UP key.

1. ➤ Remove the pressure hose from the metering pump for acid.
2. ➤ Note the stroke length of the metering pump and set it to a stroke length of 100%.
3. ➤ On the controller, change to the 'Acid priming' selection menu using the Change key
4. ➤ Press the UP key
  - ⇒ The pump pumps for approx. 30 s each time the key is pressed.
5. ➤ When feed chemical is visible at the pressure connector, stop priming immediately using the UP key and fit the pressure hose onto the metering pump
6. ➤ Re-adjust the stroke length of the metering pump to the noted value

**Priming disinfectant (with liquid ends with bleed valve):**

1. ➤ Open the metering pump bleed valve for disinfectant a little
2. ➤ Note the stroke length of the metering pump and set it to a stroke length of 100%.
3. ➤ On the controller, change to the 'Prime oxidate' selection menu using the Change key
4. ➤ Press the UP key
  - ⇒ The pump pumps for approx. 30 s each time the key is pressed.
5. ➤ When feed chemical is visible at the pressure connector, stop priming immediately using the UP key and close the metering pump bleed valve
6. ➤ Re-adjust the stroke length of the metering pump to the noted value
7. ➤ Re-start the control process: change to the continuous display using the Change key and start the controller using the START/STOP key

## 6.3 Calibration



*You have to regularly calibrate the pH sensor during operation. That means: 24 hours after initial calibration and then weekly thereafter.*

*Please take into account any differing national regulations.*

*Only calibrate the pH sensor with the quality buffer solutions pH 7 and pH 4.*

**Preparing the filtration circuit****WARNING!****Danger from hazardous substances!**

Possible consequence: Fatal or very serious injuries.

Please ensure when handling hazardous substances that you have read the latest safety data sheets provided by the manufacturer of the hazardous substance. The actions required are described in the safety data sheet. Check the safety data sheet regularly and replace, if necessary, as the hazard potential of a substance can be re-evaluated at any time based on new findings.

The system operator is responsible for ensuring that these safety data sheets are available and that they are kept up to date, as well as for producing an associated hazard assessment for the workstations affected.

There must be a chlorine concentration of approx. 0.5 ... 0.8 mg/l in the pool to be able to calibrate the sensors.

Example (without depletion losses): A swimming pool contains 60 m<sup>3</sup>, by way of example. To obtain a chlorine concentration of 0.5 ... 0.8 mg/l in this swimming pool, requires 0.20 ... 0.32 litres of 12 % sodium-calcium hypochlorite (density (ρ) 1.22 ± 0.02).

➤ Meter in the required quantity of sodium-calcium hypochlorite into the filtration circuit, either using the chlorine metering pump or evenly distribute the quantity of sodium-calcium hypochlorite needed into the swimming pool using a measuring cup.

⇒ An even concentration can be expected once the reaction time has elapsed:

$$\text{reaction time [h]} = \text{cup contents [m}^3\text{]} / \text{circulation capacity [m}^3\text{/h]}$$

## Preparation for calibration and calibration

You need the following materials:

- Spray bottle with distilled water
- Clean, soft cloth
- Buffer solution pH 7 (50 ml)
- Buffer solution pH 4 (50 ml)

For this purpose, prepare for removal of the pH sensor, see the operating instructions for the sensors and the in-line probe housing.



Once the controller jumps to the continuous display '1' following calibration, press the [Start/Stop] key once, [O] appears. Otherwise the pumps can start up before your system is ready for use again. Apart from that, the system can be damaged if the pumps are working against a shut-off valve.

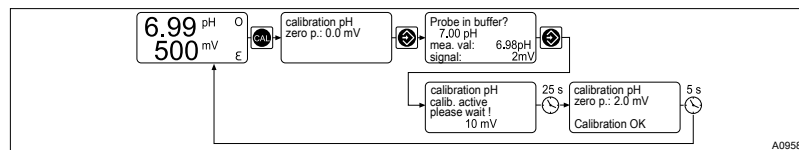



Fig. 7: The controller's pH sensor calibration display

1. ▶ Press the [CAL] key in the continuous display
  - ⇒ The calibration menu appears.
2. ▶ Press the [ENTER] key
  - ⇒ The menu item [Probe in buffer?] appears and metering stops.
3. ▶ Close both shut-off valves
4. ▶ Unscrew the SN 6 plug from the pH sensor
5. ▶ Unscrew the pH sensor from the in-line probe housing
6. ▶ Screw the SN 6 plug onto the pH sensor
7. ▶ Rinse the pH sensor with distilled water and dab it with a dry, soft cloth.
8. ▶ Dip the pH sensor in pH 7 buffer solution and stir
9. ▶ Press the [ENTER] key
  - ⇒ The menu item [calibration pH calib. active] appears
10. ▶ After approximately 25 seconds the menu item [calibration pH appears. Zero p. ... calibration OK]
  - ⇒ If another message appears, note it down and call service.
11. ▶ After 5 seconds the display jumps back to the continuous display '1'
12. ▶ Immediately press the [Start/Stop] key once
  - ⇒ [O] appears.
13. ▶ Unscrew the SN 6 plug from the pH sensor
14. ▶ Screw the pH sensor into the in-line probe housing
15. ▶ Screw the SN 6 plug onto the pH sensor
16. ▶ Open the shut-off valves
17. ▶



Are the shut-off valves open?

Press the [START/STOP] key once

⇒ [O] disappears.

## Preparation for calibration and calibration

You need the following materials:

- Spray bottle with distilled water
- Clean, soft cloth
- Buffer solution 465 mV (50 ml)

To this end, prepare for removal of the ORP sensor, see the operating instructions for the sensors and the in-line probe housing.



*Continuous display '1': press the [Start/Stop] key once, [O] appears. Otherwise the pumps can start up before your system is ready for use again. Apart from that, the system can be damaged if the pumps are working against a shut-off valve.*

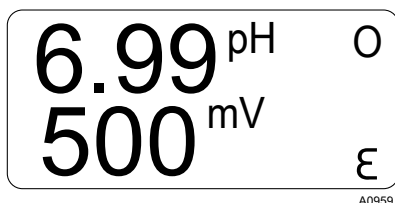

Fig. 8: ORP (mV) and pH

1. ➔ Close both shut-off valves
2. ➔ Unscrew the SN 6 plug from the ORP sensor
3. ➔ Unscrew the ORP sensor from the in-line probe housing
4. ➔ Screw the SN 6 plug onto the ORP sensor
5. ➔ Rinse the ORP sensor with distilled water and dab it with a dry, soft cloth.
6. ➔ Immerse the ORP sensor in 465 mV buffer solution (50 ml) and check the mV indication on the controller display.
  - ⇒ If the value lies outside the range 435 to 490 mV, replace the ORP sensor.
7. ➔ Unscrew the SN 6 plug from the ORP sensor
8. ➔ Screw the ORP sensor into the in-line probe housing
9. ➔ Screw the SN 6 plug onto the ORP sensor
10. ➔ Open the shut-off valves
11. ➔



*Are the shut-off valves open?*

Press the [START/STOP] key once

⇒ [O] disappears.

## 7 Maintenance and faults



*Flush the metering system with a suitable flushing medium prior to maintenance - refer to the latest safety data sheets for the feed chemical.*

*Observe the operating instructions for the metering pump, the in-line probe housing, the sensors, dirt filter and multi-functional valve (optional).*

### 7.1 Maintenance work

An overview of maintenance work

Maintenance interval	Maintenance task
daily	Check swimming pool water values
weekly	Visual inspection of metering system (flow meter)
	Check storage tank liquid/powder levels
	Check sensor
6 months	Clean valves

Maintenance interval: daily



*You must check the actual swimming pool water values daily to guarantee the safe operation of your swimming pool system.*

1. ➔ Check the chlorine concentration using the DPD test (refer to the operating instructions for the test kit)
2. ➔ Check the pH value using the phenol red test (refer to the operating instructions for the test kit)
  - ⇒ If the swimming pool water values lie outside the tolerance limits, then conduct additional tests, as described in ↗ 'An overview of maintenance work' Table on page 24.

Maintenance interval: weekly

1. ➔ Regularly conduct a visual inspection of the metering system, specifically the sensors and the flow meter with flow sensor for:
  - Air bubbles in the sample water
  - The state of the sensors
  - Leakages
  - Correct flow values
  - To ascertain whether the flow sensor is fastened correctly onto the flow meter
  - To ascertain whether the float is moving easily within the flow meter: To do so, note down the flow value and then change the flow value - the float should change position
  - ⇒ Call Customer service if one of these points is not correct.
2. ➔ Check the liquid/powder levels in the storage tanks
  - ⇒ Pour in feed chemical if the liquid/powder level has fallen below 10 cm.
3. ➔ Check the sensors by calibrating them

Maintenance interval: 6 months

Clean dirt filter regularly:

1. ➔ Close the stopcocks upstream and downstream of the in-line probe housing
2. ➔ Unscrew the filter bowl
3. ➔ Remove the filter insert and clean it without detergent
4. ➔ Insert the filter insert into the housing
5. ➔ Check the sealing ring and the sealing surfaces for cleanliness, and clean if necessary
6. ➔ Screw the filter bowl until tight
7. ➔ Open the stopcocks on the in-line probe housing

## 7.2 Check sensors

Preparation for testing and testing - pH

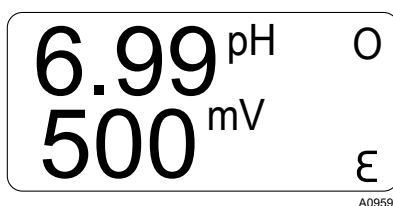

Fig. 9: ORP (mV) and pH

You need the following materials:

- Spray bottle with distilled water
- Clean, soft cloth
- Buffer solution pH 7 (50 ml)
- Buffer solution pH 4 (50 ml)

For this purpose, prepare for removal of the pH sensor, see the operating instructions for the sensors and the in-line probe housing.



*Continuous display '1': press the [Start/Stop] key once, [O] appears. Otherwise the pumps can start up before your system is ready for use again. Apart from that, the system can be damaged if the pumps are working against a shut-off valve.*

1. ➔ Close both shut-off valves
2. ➔ Unscrew the SN 6 plug from the pH sensor
3. ➔ Unscrew the pH sensor from the in-line probe housing
4. ➔ Screw the SN 6 plug onto the pH sensor
5. ➔ Rinse the pH sensor with distilled water and dab it with a dry, soft cloth.
6. ➔ Dip the pH sensor in pH 7 buffer solution and stir
  - ⇒ Check the value on the controller display: Is the value between 6.8 and 7.2?
7. ➔ Rinse the pH sensor with distilled water and dab it with a dry, soft cloth.
8. ➔ Dip the pH sensor in pH 4 buffer solution and stir
  - ⇒ Check the value on the controller display: Is the value between 3.8 and 4.2?

If one value lies outside the tolerance of  $\pm$  pH 0.2, a calibration must be carried out.

Call Customer service if both values are outside tolerance.
9. ➔ Unscrew the SN 6 plug from the pH sensor
10. ➔ Screw the pH sensor into the in-line probe housing
11. ➔ Screw the SN 6 plug onto the pH sensor
12. ➔ Open the shut-off valves

13. ▶



*Are the shut-off valves open?*

Press the [START/STOP] key once

⇒ [O] disappears.

### Preparation for testing and testing - pH

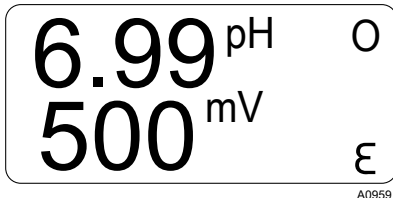

Fig. 10: ORP (mV) and pH

You need the following materials:

- Spray bottle with distilled water
- Clean, soft cloth
- Buffer solution 465 mV (50 ml)

To this end, prepare for removal of the ORP sensor, see the operating instructions for the sensors and the in-line probe housing.



*Continuous display '1': press the [Start/Stop] key once, [O] appears. Otherwise the pumps can start up before your system is ready for use again. Apart from that, the system can be damaged if the pumps are working against a shut-off valve.*

1. ▶ Close both shut-off valves
2. ▶ Unscrew the SN 6 plug from the ORP sensor
3. ▶ Unscrew the ORP sensor from the in-line probe housing
4. ▶ Screw the SN 6 plug onto the ORP sensor
5. ▶ Rinse the ORP sensor with distilled water and dab it with a dry, soft cloth.
6. ▶ Dip the ORP sensor in a 465 mV buffer solution
  - ⇒ Check the value on the controller display: Is it between 435 ... 490 mV?  
Call Customer service if the value is outside tolerance.
7. ▶ Unscrew the SN 6 plug from the ORP sensor
8. ▶ Screw the ORP sensor into the in-line probe housing
9. ▶ Screw the SN 6 plug onto the ORP sensor
10. ▶ Open the shut-off valves
11. ▶



*Are the shut-off valves open?*

Press the [START/STOP] key once

⇒ [O] disappears.

## 7.3 Troubleshooting

Use the operating instructions for controllers, sensors, in-line probe housings, metering pumps and multifunctional valves (optional) to eliminate functional faults or call Customer service.

## 7.4 Disposal of used parts

- **Users' qualification:** instructed persons, see [Chapter 3.1 'Users' qualifications'](#) on page 9



### NOTICE!

#### Regulations governing disposal of used parts

- Note the current national regulations and legal standards which apply in your country

ProMinent Dosiertechnik GmbH, Heidelberg will take back decontaminated used devices providing that they are covered by adequate postage.

## 8 Technical data



Refer to the product-specific operating instructions for technical data on the controller, sensors, in-line probe housing, metering pump and multifunctional valve.

### Maximum permissible operating pressure

- In the sample water line: 2 bar at 30 °C (sample water)

### Sample water line connector

- 8x5 mm PE tube

### Sample water filter element

- 300 µm

### Weights

- with pumps: approx. 10 kg
- without pumps: approx. 6 kg

### Material

- Plate material: PP
- Materials, wetted: The wetted materials are resistant to the media commonly used in swimming pools. Consult the operating instructions for the individual components with other media.
- Sample water filter: polypropylene, nylon, nitrile rubber, stainless steel

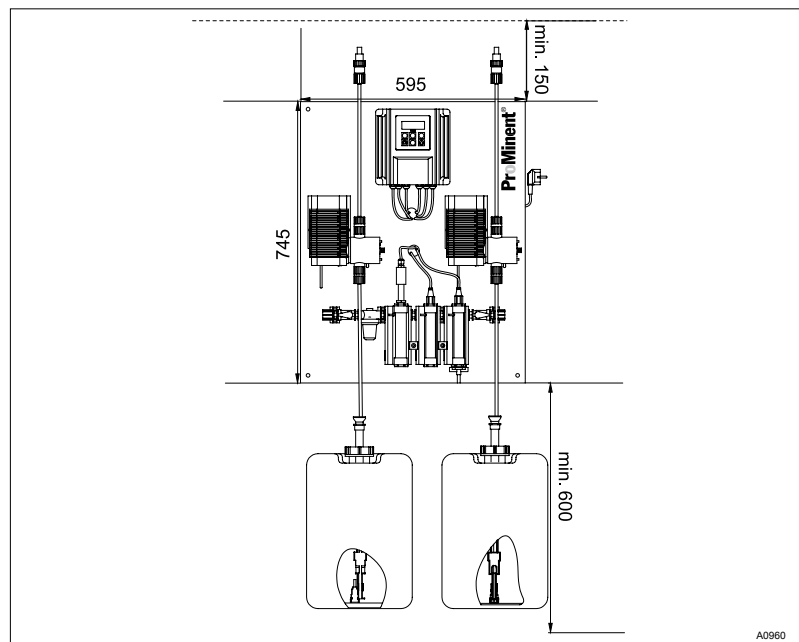

Fig. 11: Dimensions sheet. All dimensions in mm. Depth 150 mm

## 9 Systems

### 9.1 Spare parts and accessories

#### Spare parts

Spare parts	Part no.
pH sensor PHES 112 SE	150702
Buffer solution pH 7, 50 ml	506253
Buffer solution pH 4, 50 ml	506251
Redox sensor RHES-Pt-SE	150703
Buffer solution 465 mV, 50 ml	506240
Acid metering pump spare parts kit (PP):	
ALPc 1002 PPE ...	1001647
ALPc 1004 PPE ...	1001647
Spare tube, complete, PharMed® for DULCO® flex	1009480
Chlorine metering pump spare parts kit (clear acrylic):	
ALPc 1002 NPB ...	1001724
ALPc 1004 NPB ...	1001724
Spare tube, complete, PharMed® for DULCO® flex	1009480
Filter element 300 µm, stainless steel	1038867

#### Accessories

Accessories	Part no.
Photometer: To detect free, bound and total chlorine	1003473

## 9.2 EC Declaration of Conformity

EC Declaration of Conformity	
We hereby declare,	<b>ProMinent Dosiertechnik GmbH</b> <b>Im Schuhmachergewann 5 - 11</b> <b>D - 69123 Heidelberg</b>
<p>that the following designated product complies with the pertinent fundamental safety and health requirements of the EC Directive in terms of its design and construction and in terms of the version marketed by us.                      This declaration loses its validity in the event of a modification to the product not agreed with us.</p>	
Description of the product:	Dosing system for swimming pool DULCODOS POOL
Product type:	DSPA ----- X - X - 1 - DSPA ----- X - X - 1 - DSPA ----- X - X - 1 - and X ≠ 0 i.e. for assembled systems with at least one dosing pump ex works
Serial no.:	refer to nameplate on the device
Pertinent EC Directives:	EC Machinery Directive (2006/42/EC) EC Low Voltage Directive (2006/95/EC) EC EMC Directive (2004/108/EC)
Applied harmonised standards in particular:	EN ISO 12100-1, EN ISO 12100-2, EN 809 EN 60335-1, EN 61010-1, EN 61000-6-1, EN 61000-6-2, EN 61000-6-3, EN 61000-6-4
technical documents have been compiled by:	Norbert Berger Im Schuhmachergewann 5-11 DE-69123 Heidelberg
Date / Manufacturer - Signature :	04.01.2010 
Details of the signatory:	Joachim Schall, Head of Research and Development

Fig. 12: EC Declaration of Conformity

## 10 Index

<b>A</b>		
Ambient conditions.....	13	
<b>G</b>		
General non-discriminatory approach.....	3	
<b>N</b>		
non-discriminatory approach.....	3	
<b>Q</b>		
Question: For what purpose is this product intended?....	7	Question: What components does the product include?. 7
Question: How and why must I calibrate the product?..	21	Question: What do I need to consider when operating the product for the first time?.....
Question: How can I store and transport the product?..	13	19
Question: How do I calibrate the pH sensor?.....	22	Question: What options are available in terms of "Maintenance and faults"?.....
Question: How do I eliminate functional faults?.....	26	24
Question: How do I test the ORP sensor?.....	23, 26	Question: What should I consider when mounting the product on the wall?.....
Question: How do I test the pH sensor?.....	25	14
Question: How is the product hydraulically connected and what connection versions are available?....	15	Question: What type of buffer solutions do I need? .....
Question: What ambient conditions need to be taken into consideration?.....	13	22, 23, 25, 26
		<b>S</b>
		Safety information.....
		9
		Storage.....
		13
		<b>T</b>
		Transport.....
		13
		<b>U</b>
		Users' qualifications.....
		9