

Assembly and operating instructions

DULCOMARIN® II, P-Module

(Power Supply Module with Relay) DXMaP

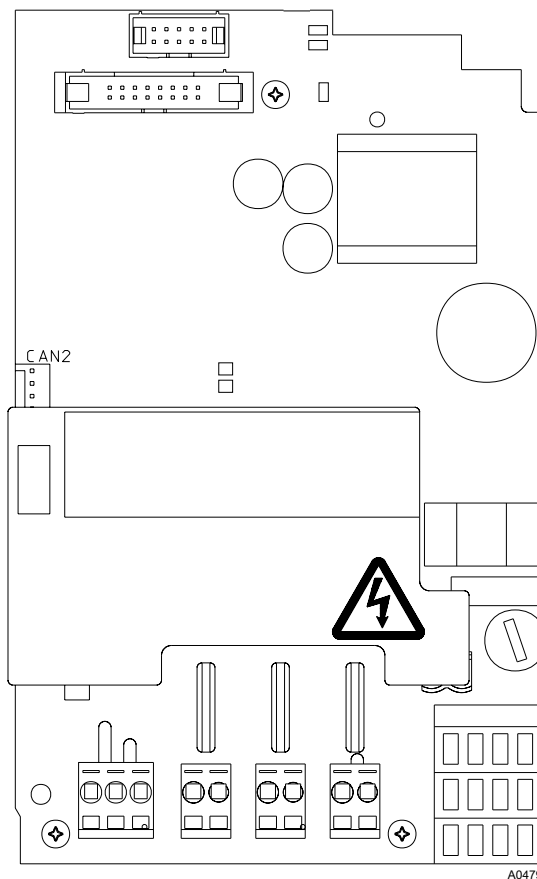

Please enter the identity code of your device here! DXMa _____

**Please carefully read these operating instructions before use! · Do not discard!
The operator shall be liable for any damage caused by installation or operating errors!
Technical changes reserved.**

ProMinent Dosiertechnik GmbH
Im Schuhmachergewann 5 - 11
69123 Heidelberg
Telephone: +49 6221 842-0
Fax: +49 6221 842-419
email: info@prominent.de
Internet: www.prominent.com

986903, 1, en_GB

Further applicable documents

These operating instructions and supplementary instructions are only valid in combination with the following operating and supplementary instructions:

- Multi-channel measuring and control system operating instructions DULCOMARIN® II Swimming Pool Controller and Disinfection Controller DXCa Part 1: Assembly and installation
- Multi-channel measuring and control system operating instructions DULCOMARIN® II Swimming Pool Controller and Disinfection Controller DXCa Part 2: Operation

Table of contents

1	Identity code	5
2	About this device	7
	2.1 Safety chapter.....	7
	2.2 Storage and transport.....	7
3	Assembly and installation	8
	3.1 Repairs (fuse change only).....	10
	3.2 Arrangement of LEDs.....	11
	3.3 Example for connection of a solenoid valve.....	12
4	Technical data	13

1 Identity code



The identity code describes the external modules for the DULCOMARIN® II, series DXM

Only the M module of mounting type "W" "Wall mounting" can be ordered with operating elements and with different languages.

DXMa	External modules for the DULCOMARIN® II, series DXM	
		Module:
M		M module, measuring module: pH, redox, temperature
A		A module, control module: 3 pumps and 4 analog outputs
R		R module, control module: Chlorine gas metering device with feedback ^{1) 2)}
N		N module, power supply module without relay ^{1) 2)}
P		P module, power supply module without relay, only mounting type "0)" ²⁾
I		I module, current input module, 3 mA inputs, 2 digital inputs
		Mounting type:
	0	Without housing, only P-module (IP 00)
	W	Wall mounted (IP 65)
	H	Mounting rail (IP 20)
	E	Upgrade module (insert module for DXCa, IP 20)
		Version:
	0	With controls
	2	Without controls
	3	Without controls (only mounting type "E")
		Application:
	0	Standard
	S	Swimming pool (only m module)
		Language:
	00	No controls ²⁾
	DE	German
	EN	English
	ES	Spanish
	FR	French
	IT	Italian
		Certification:

Identity code

DXMa	External modules for the DULCOMARIN® II, series DXM						
							00 No certification, only P-module without housing
							01 CE mark

¹⁾ only mounting type W wall mounting / ²⁾ only in version "2" without controls

2 About this device

The power supply module with relay DXMaP with alarm relay and solenoid valve relay supplies the DULCOMARIN® II compact with mains voltage and allows it to control 3 solenoid valves or hose pumps via pulse frequency e.g. to:

- raise / lower the pH value
- meter disinfectant
- meter flocculant
- minimise combined chlorine

The DXMaP power supply module has the following outputs:

- power relay for alarm output
- power relay output for solenoid valve or hose pump (pH correction)
- power relay output for solenoid valve or hose pump (disinfectant)
- power relay output for hose pump (flocculant) or relay output (minimising of combined chlorine)
- one mains input

2.1 Safety chapter



CAUTION!

Safety when using the P module

- The DXMaP power supply module with relay must only be used to control alarm horns, solenoid valves and hose pumps as well as to provide the power supply for the DULCOMARIN® II DXCa.
- The DXMaP power supply module with relay must only be used as part of the DULCOMARIN® II.
- The installation must only be carried out by technically trained personnel.

2.2 Storage and transport



CAUTION!

Protect the module against moisture and the effects of chemicals, even while still packaged.

Store and transport the module in its original packaging.

Ambient conditions for storage and transportation:

- Temperature: -10 °C ... 70 °C
- Max. permissible relative humidity: 95 %, non-condensing (DIN IEC 60068-2-30)

3 Assembly and installation



NOTICE!

The installation must only be carried out by technically trained personnel.

When assembling and installing this device, observe the instructions in the operating instructions "Multi-channel measuring and control system DULCOMARIN® II Swimming Pool Controller and Disinfection Controller DXCa Part 1: Assembly and installation".

Make the CAN connection according to the "Multi-channel measuring and control system operating instructions DULCOMARIN® II Swimming Pool Controller and Disinfection Controller DXCa Part 1, Assembly and Installation".

Terminal allocation

Description	Terminal identifier	Terminal no.	Pol	Function
Alarm relay	P1	1		Alarm horn (control)
		2		
		3		
Power relay 1	P2	4		PWM pH-lowerer (control solenoid valve DULCO®flex)
		5		PWM pH-raiser (control)
Power relay 2	P3	6		free
		7		PWM chlorine PWM ORP PWM alkaline PWM acid Backwashing
Power relay 3	P4	8		UV system enable
		9		PWM chlorine (control) PWM ORP (control) Heating enable
Power supply	X1	10	PE	
		11	N	
		12	L(1)	

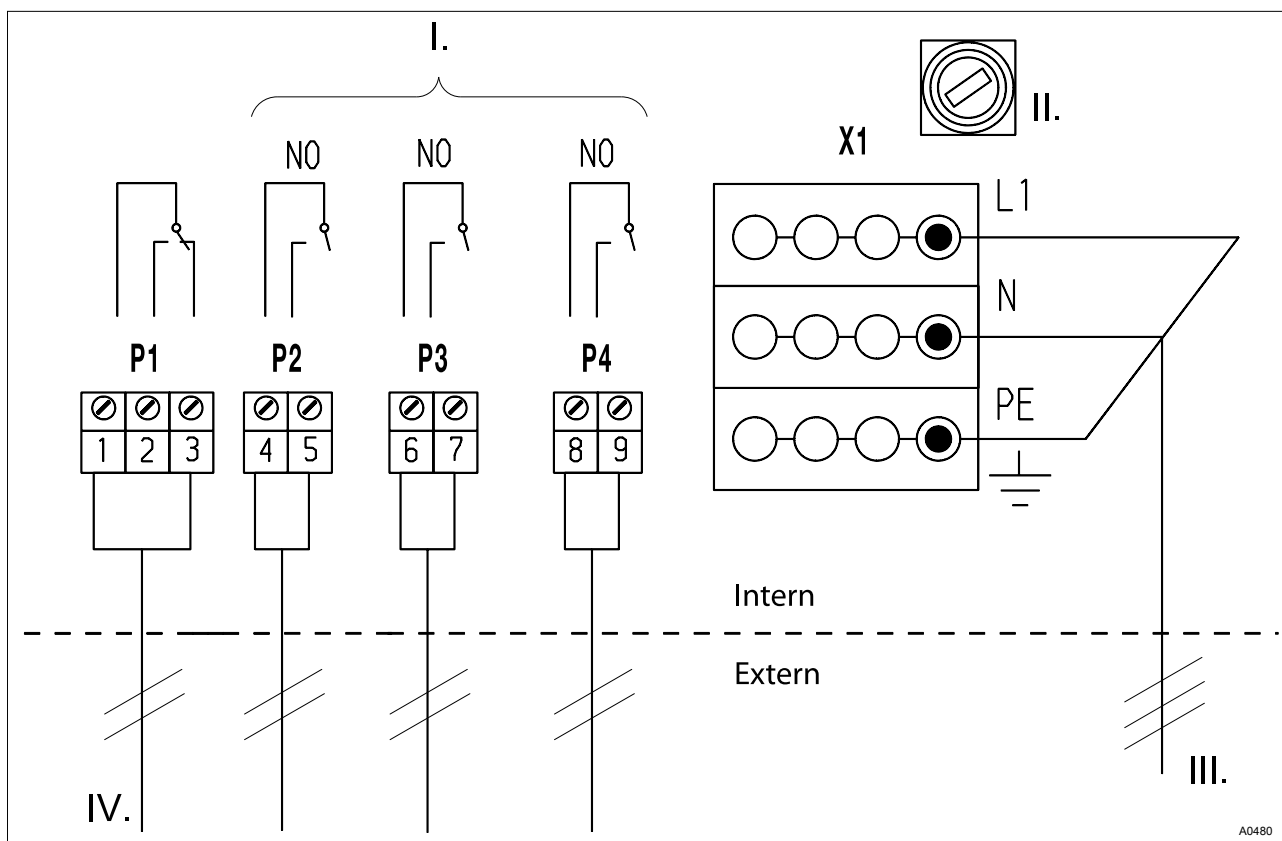

Fig. 1: Terminal Wiring Diagram

- I. Power relay
- II. Fuse 0.63 A, slow-acting
- III. Supply Voltage
- IV. Alarm (horn)

Power supply module

Locate the power supply module in the CAN bus backbone (DUL-COMARIN® II DULCO-Net)

The central unit always contains a power supply module.

Number of pools	Additional N- or P-modules	Number of pools	Additional N- or P-modules
1	-	9	4
2	-	10	5
3	1	11	5
4	2	12	6
5	2	13	6
6	3	14	7
7	3	15	7
8	4	16	8

(Exception: number of pools = 2)



The two LEDs (LED 1 and LED 2) indicate the load of the 24V power supply for the CAN bus.

Flash code LEDs power supply monitoring DULCOMARIN® II (N and P module)

Operating status	LED 1 (H2, power)	LED 2 (H3, power)	Power	Remarks
Normal	off	green	< 1.1 A	All OK
Limit load	red	off	> 1.1 A	Insert another power supply module into the loop
Overload / short circuit	red, flashing	off	> 1.35 A	Check wiring

3.1 Repairs (fuse change only)



WARNING!

Mains voltage

Possible consequence: Fatal or very serious injuries.

External fuse necessary.

If mains voltage is connected to the device, then the fuse carrier is also under mains voltage.

Before working on the device, disconnect the device from the mains voltage and secure to prevent switching back on.



NOTICE!

The fuse only may be replaced by technically trained personnel. All other repair work may only be carried out by Customer Service.

Otherwise, general safety regulations apply.

Use only original fuses: Micro fuse 5 x 20 mm, 630 mA, 250 V, slow-acting (Order No. 712030).

3.2 Arrangement of LEDs

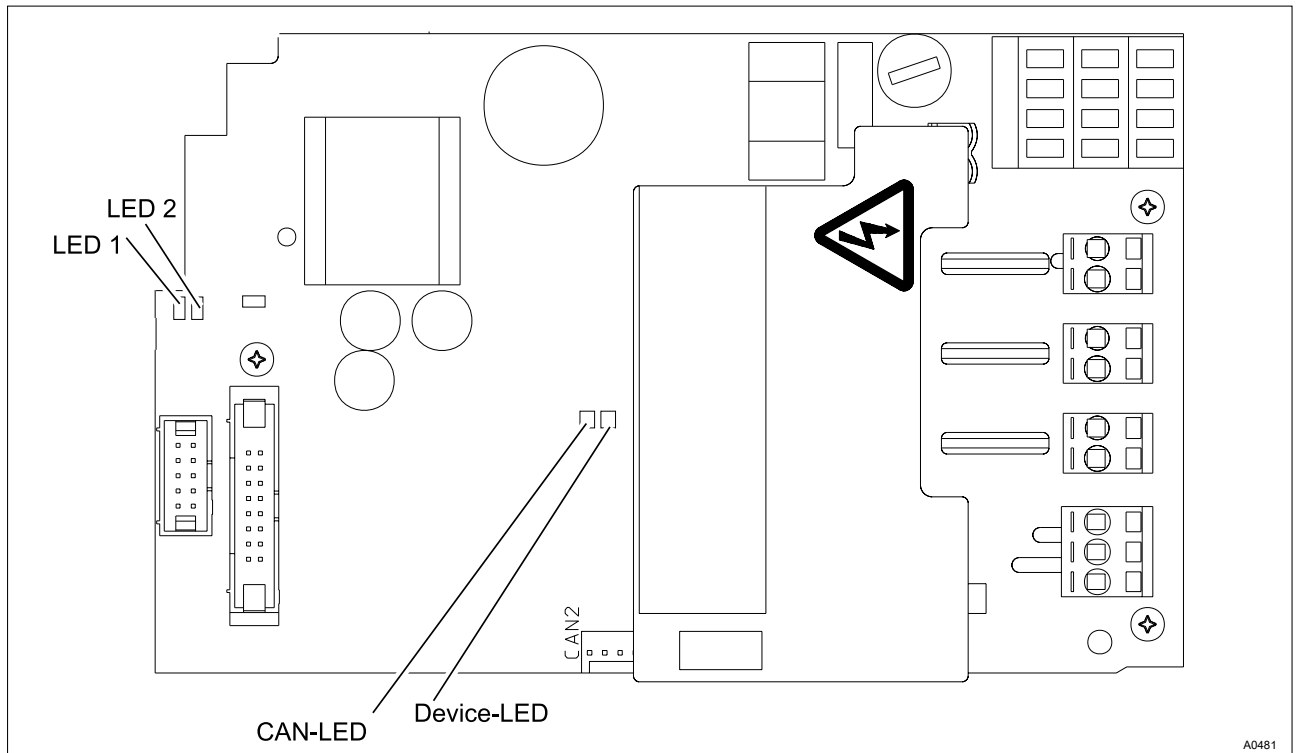

Fig. 2: Arrangement of LEDs

3.3 Example for connection of a solenoid valve



WARNING!
External fuse necessary

Example for connection of a solenoid valve (or hose pump DULCO®flex DF2a or alpha motor-driven metering pump).

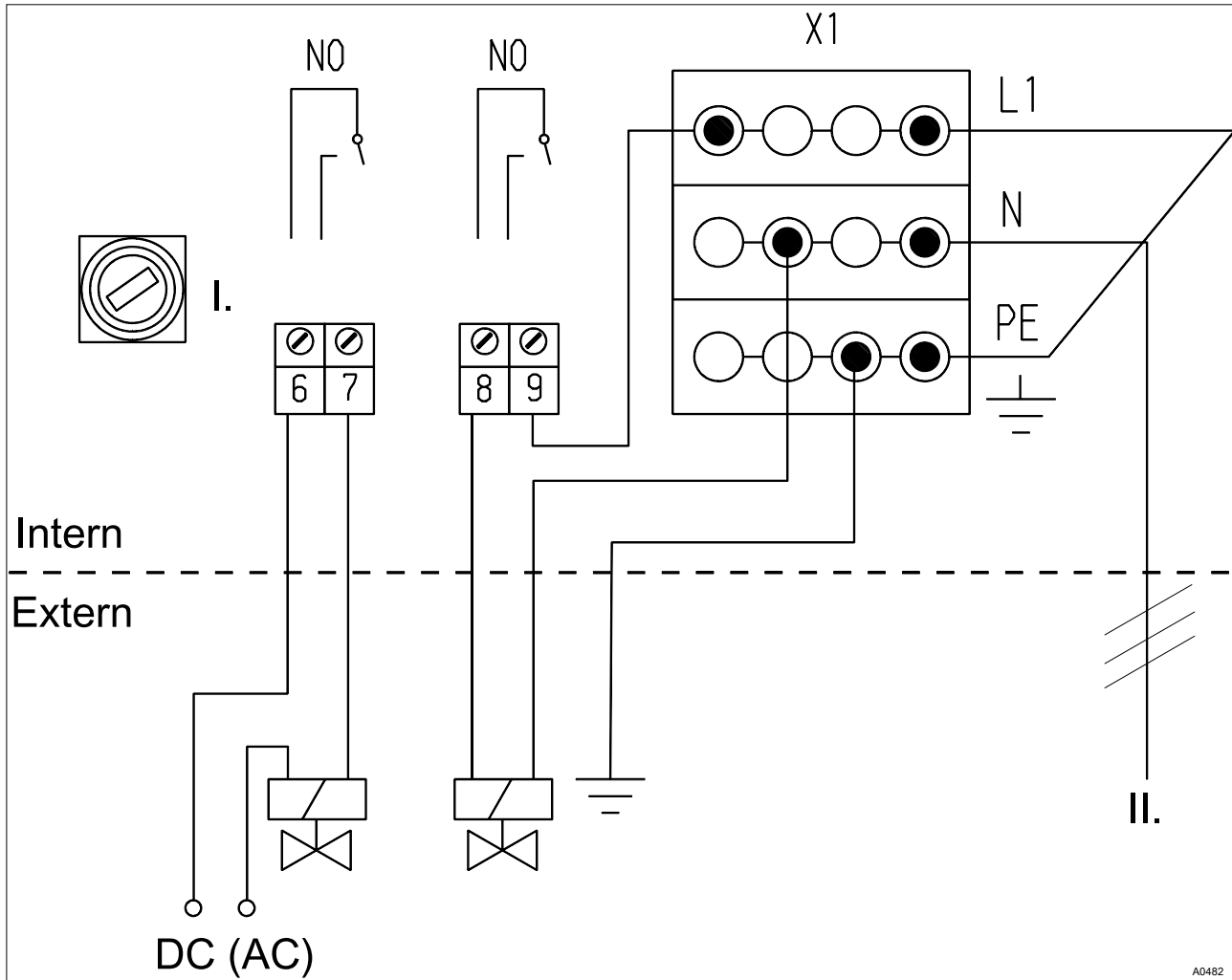

Fig. 3: Example for connection of a solenoid valve

- I. Fuse 0.63 A, slow-acting
- II. Mains connection

4 Technical data

Electrical data



The DXMaP power supply module with relay contains the 24 V DC, 1 A direct current power supply unit.

Power relay for alarm output (P1):

- Type of contact: Changeover contact with interference-suppressed varistors
- Load capacity: 250 V AC, 3 A max., 700 VA
- Contact lifespan: > 10⁵ switching operations (at 3 A)

Power relay output for control variable output or limit value reporting (P2 - P4):

- Type of contact: N/O contact with varistors, interference-suppressed
- Load capacity: 250 V AC, 3 A max., 700 VA
- Contact lifespan: > 20 x 10⁶ switching operations

Nominal voltage (X1):

- 90 - 253 V AC (50 / 60 Hz)
- Maximum power consumption: 500 mA at 90 V AC // 180 mA at 253 V AC
- Internal fusing with: Micro fuse 5 x 20 mm, 630 mA, 250 V, slow-acting
- Electrical power consumption: 30 W

Degree of protection: IP 20

Ambient conditions: Storage temperature: -10...70 °C