

# Motor-Driven Metering Pump Sigma X Control Type – Sigma/ 1 - S1Cb

The new Sigma X range – reliable, smart and connectible

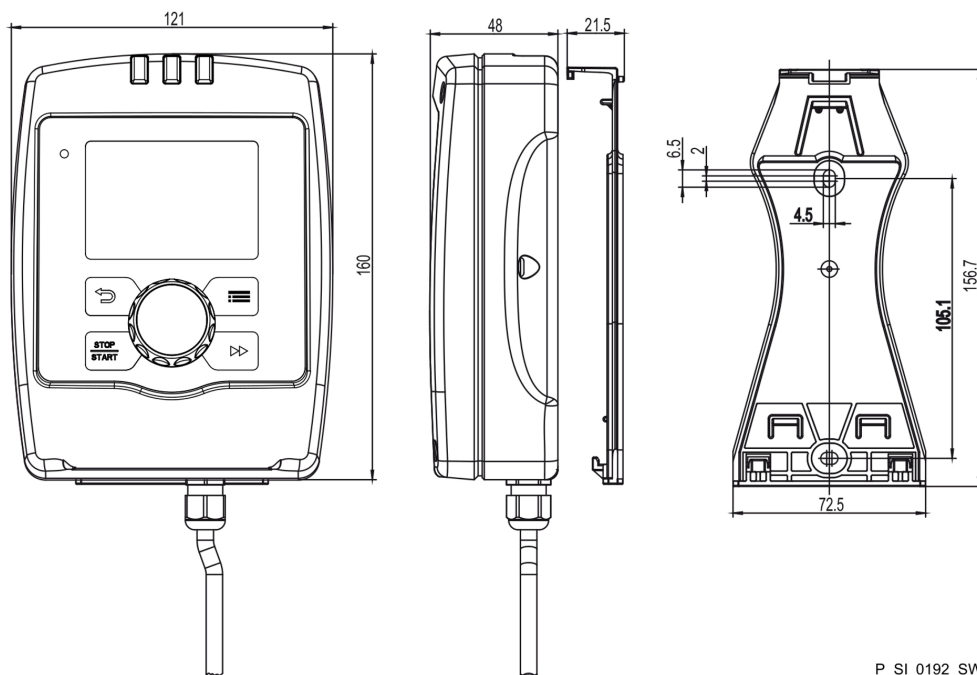

P\_SI\_0192\_SW

Exemplary representation. The dimensions depend on the configuration chosen.

The Sigma control type is a smart motor-driven metering pump that is setting new standards in terms of productivity, reliability and safety.

## Technical Details

- Stroke length: 4 mm
- Stroke length adjustment range: 0 – 100%
- Stroke length adjustment: manually using self-locking rotary dial in 1 % increments
- With the right, constant conditions, correct installation and calibration, precision exceeds  $\pm 1$  %, based on maximum stroke volume.
- Wetted materials: PVDF, stainless steel 1.4571/1.4404 (special materials on request)
- Power supply: 1-phase, 100 – 230 V  $\pm 10\%$ , 240 V  $\pm 6\%$ , 50/60 Hz (110 W)
- Degree of protection IP 65
- Fibreglass-reinforced plastic housing
- The liquid end on the left of the standard version can be selected for special installation situations or in combination with tanks, brackets etc.
- Manual or external contact mode can be set, factor with external contact control 99:1 – 1:99; batch mode with max. 99,999 strokes/start pulse.
- Metering profiles for optimum metering results.
- Display of wear parts in the Service menu.
- Connector for 2-stage level switch.
- Connection to PROFINET using the ProMinent DULCONvert PROFIBUS®-PROFINET converter.
- Various relay modules can be selected
- Variants with EU 1935/2004, FDA or hygienic design can be selected for food and other applications. Hygienic design liquid ends are available for applications with stringent hygiene requirements.
- Customised designs are available on request.

For reasons of safety, provide suitable overflow devices during installation for all mechanically deflected diaphragm metering pumps.

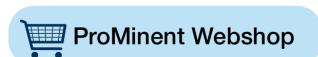

# Motor-Driven Metering Pump Sigma X Control Type – Sigma/ 1 - S1Cb

The new Sigma X range – reliable, smart and connectible

## Technical Data

Type	Capacity at max. back pressure			Max. stroke rate	Pump capacity at max. back pressure		Suction lift	Perm. pre-pressure suction side	Connector Suction/ Discharge Side	Shipping weight
	l/h	bar	ml/stroke		gph (US)	psi				
12017 PVT	21	10	3.8	90	5.5	145	7	1	3/4-10	9
12017 SST	21	12	3.8	90	5.5	174	7	1	3/4-10	12
12035 PVT	42	10	4.0	170	11.1	145	7	1	3/4-10	9
12035 SST	42	12	4.0	170	11.1	174	7	1	3/4-10	12
10050 PVT	49	10	4.0	200	12.9	145	7	1	3/4-10	9
10050 SST	49	10	4.0	200	12.9	145	7	1	3/4-10	12
10022 PVT	27	10	5.0	90	7.1	145	6	1	3/4-10	9
10022 SST	27	10	5.0	90	7.1	145	6	1	3/4-10	12
10044 PVT	53	10	5.1	170	14.0	145	6	1	3/4-10	9
10044 SST	53	10	5.1	170	14.0	145	6	1	3/4-10	12
07065 PVT	63	7	5.2	200	16.6	102	6	1	3/4-10	9
07065 SST	63	7	5.2	200	16.6	102	6	1	3/4-10	12
07042 PVT	52	7	9.5	90	13.7	102	3	1	1-15	10
07042 SST	52	7	9.5	90	13.7	102	3	1	1-15	14
04084 PVT	101	4	9.7	170	26.7	58	3	1	1-15	10
04084 SST	101	4	9.7	170	26.7	58	3	1	1-15	14
04120 PVT	117	4	9.7	200	30.9	58	3	1	1-15	10
04120 SST	117	4	9.7	200	30.9	58	3	1	1-15	14

Integrated relief valve, connector for DN 10 pressure hose sleeve

## Materials in Contact with the Medium

Identity code of material	Dosing head	Connection on suction/discharge side	Seals/ball seat	Balls	Integral relief valve
PVT	PVDF	PVDF	PTFE/PTFE	Ceramic	PVDF/FKM or EPDM
SST	Stainless steel 1.4404	Stainless steel 1.4581	PTFE/PTFE	Stainless steel 1.4404	Stainless steel/FKM or EPDM
PVF	PVDF	PVDF	PTFE/PTFE	Ceramic	PVDF/FKM or EPDM
SSF	Stainless steel 1.4404	Stainless steel 1.4581	PTFE/PTFE	Stainless steel 1.4404	Stainless steel/FKM or EPDM
SSG	Stainless steel 1.4404	Stainless steel 1.4581	PTFE/stainless steel 1.4404	Stainless steel 1.4404	-
SSH	Stainless steel 1.4435	Stainless steel 1.4435	EPDM or FKM/ stainless steel 1.4435	Ceramic	-

## Motor Data

Identity code specification	Power supply	Remarks
U	1-phase, IP 65 100 – 230 V ±10 % / 240 V ±6 % 50/60 Hz 110 W	Wide-range voltage power unit

Motors less than 0.75 kW and motors designed for speed-controllable operation are not subject to the IE3 standard in compliance with the Ecodesign Directive 2009/125/EC.